



varia Polytec

Mit einem Klick von klein zu gross

Système de réglage rapide des mors en un clic | Quick jaw-adjustment unit with one clic



Im Grossen denken -
im Kleinsten präzisieren.

varia Polytec

NEW

Mit einem Klick von klein zu gross. Schnelles Umrüsten per Knopfdruck und komplett werkzeuglos.

Système de réglage rapide des mors en un clic. Préparation rapide de l'équipement par pression d'un bouton et sans le moindre outil.

Quick jaw-adjustment unit with one click. Quick retrofitting at the press of a button, completely without tools.

BOHRUNG SEITENANSCHLAG

Seitenanschlag geschraubt oder magnetisch montierbar.

ALÉSAGE BUTÉE LATÉRALE

Butée latérale vissée ou montage magnétique.

BOREHOLE, LATERAL STOP

Lateral stop screwed or can be mounted magnetically.

ABDECKUNG

Zum Schutz der Spanneinsatztaschen.

CACHE

Pour protéger les poches d'inserts de serrage.

COVER

For the protection of the clamping insert pockets.

AUFSATZBACKENGEOMETRIE

Beste Zugänglichkeit durch optimierte Aufsatzbackengeometrie.

GÉOMÉTRIE DES MORS RAPPORTÉS

Accès idéal grâce à la géométrie optimisée des mors rapportés.

TOP JAW GEOMETRY

Best accessibility thanks to optimized top jaw geometry.

SPANNEINSÄTZE

Mit den hemo Grip Spanneinsätzen ist kein Vorprägen nötig. Weitere Spanngeometrien erhältlich.

GÉOMÉTRIE DE SERRAGE

Grâce à la géométrie de serrage du système hemo Grip, pas besoin de pré-gaufrage. Autres géométries de serrage disponibles.

CLAMPING GEOMETRY

Pre-stamping is not necessary with the hemo Grip clamping geometry. Other clamping geometries available.

GRUNDBACKEN

Die Grundbacken sind wendbar und mit einem Backenschnellwechselsystem, sowie einer Backenschnellverstellung ausgerüstet. Das angepasste Führungsverhältnis erhöht die Stabilität und die Präzision des Spanners. Die komplette Grundbackenführungs-länge ist bei jeder Spannweite vollständig auf der Grundplatte.

MORS DE BASE

Les mors de base sont réversibles et équipés de deux systèmes à action rapide pour le changement et le réglage des mors. Le guidage au rapport ajusté augmente la stabilité et la précision du système de serrage. La longueur totale de guidage des mâchoires de base se trouve entièrement sur la plaque de base à chaque travée.

BASE JAWS

The base jaws can be reversed and are equipped with a quick jaw-changing system, as well as a quick jaw-adjustment unit. The adapted guidance ratio enhances the stability and precision of the clamping vice. The complete base jaw guidance length is completely on the base plate with every span.

GRUNDPLATTE

Die Bauweise garantiert höchste Steifigkeit ohne Verformung der Grundplatte. Es stehen diverse Standard-Adapterbohrbilder zur Auswahl. Kompatibel zu speed.change 30, EROWA und Quickpoint 96.

PLAQUE DE BASE

La structure garantit une extrême rigidité sans déformation de la plaque de base. Divers calibres de perçage standards sont disponibles à la sélection. Compatible avec speed.change 30, EROWA et Quickpoint 96.

BASE PLATE

The design ensures maximum rigidity without deforming the base plate. There are various standard adapter drilling patterns to choose from. Compatible with speed.change 30, EROWA and Quickpoint 96.

SPINDEL

Obenliegende Spindel für höchste Haltekräfte. Freiliegend, dadurch schmutzunempfindlich.

BROCHE

Broche en hauteur pour forces de maintien maximales. Non encastrée et donc insensible à la saleté.

SPINDLE

Top-lying spindle for maximum holding forces. Exposed, and therefore dirt resistant.

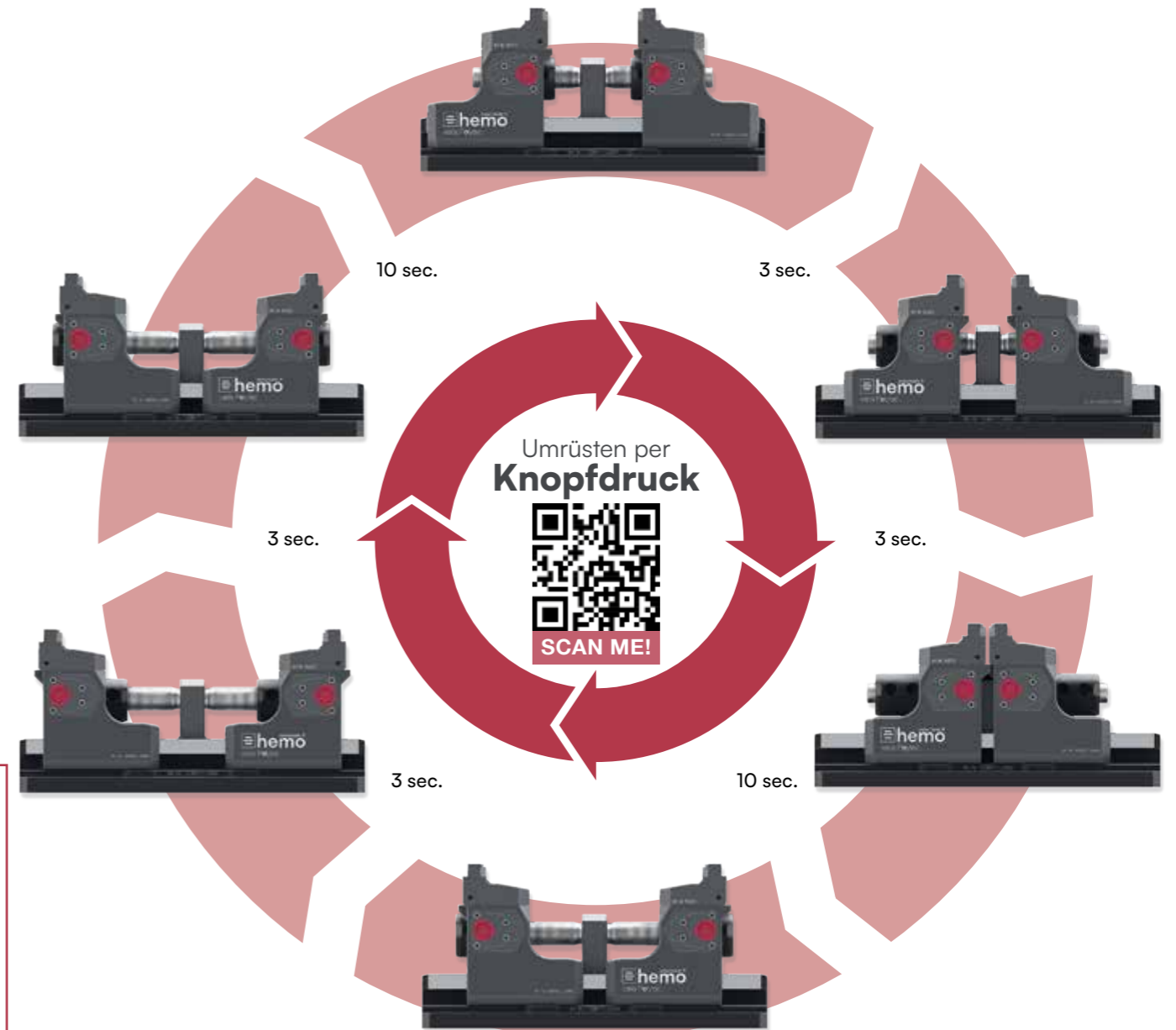
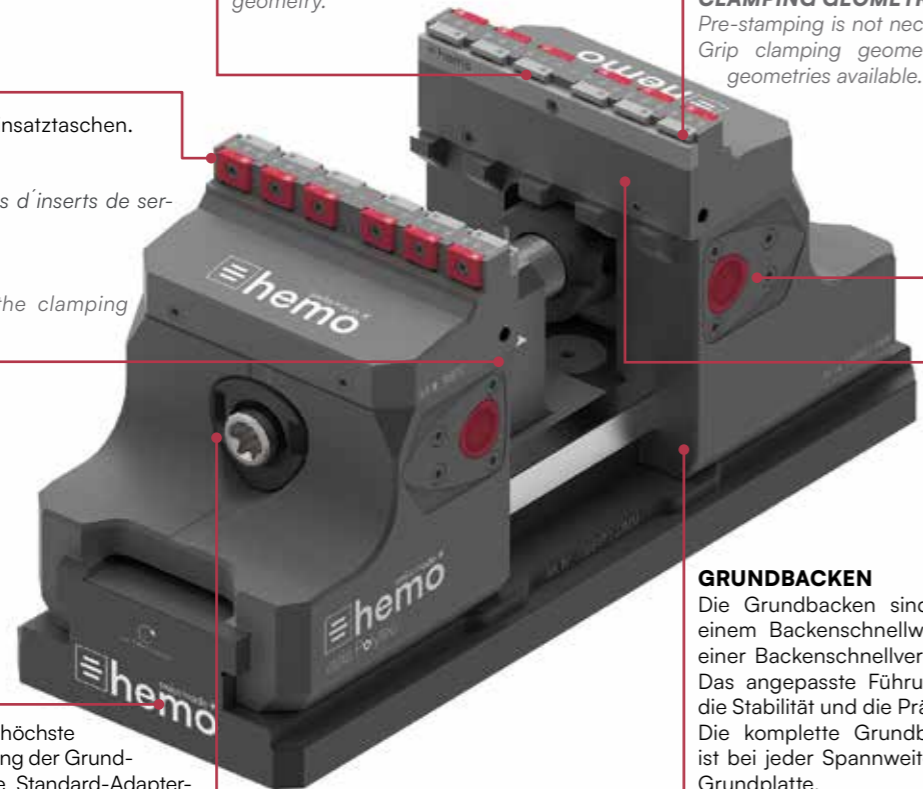

MIT EINEM KLICK

Schnelles Umrüsten per Knopfdruck und komplett werkzeuglos. Die hemo Backenschnellverstellung ermöglicht ein Umrüsten von der minimalen zur maximalen Spannweite in Sekundenschnelle.

SYSTÈME DE RÉGLAGE RAPIDE DES MORS EN UN CLIC

Préparation rapide de l'équipement par pression d'un bouton et sans le moindre outil. Le système de réglage rapide des mors hemo permet une préparation de l'équipement avec une portée de minimum à maximum en quelques secondes.

QUICK JAW-ADJUSTMENT UNIT WITH ONE CLICK

Quick retrofitting at the press of a button, completely without tools. The hemo quick jaw-adjustment unit allows retrofitting from the minimum to maximum span in a matter of seconds.

AUFSATZBACKEN

Diese sind werkzeuglos wendbar. Innert Sekunden kann die Spannweite verändert werden.

MORS RAPPORTÉS

Ces modèles sont réversibles sans outil. L'ouverture de serrage peut être modifiée en quelques secondes.

TOP JAWS

These can be turned without tools. The clamping width can be changed within seconds.



Vorteile:

- Beste Zugänglichkeit
- Schnelles Umrüsten per Knopfdruck und komplett werkzeuglos
- Höchste Haltekräfte
- Schmutzunempfindlich, allseitig freier Spänefluss
- Austauschbare und Mehrfachverwendbare Spanneinsätze mit verschiedenen Konturen
- Adapterbohrungen im Standard auf speed.change 30 und weitere Nullpunktspann- und Palettiersysteme
- Für die Roh- und Fertigteilspannung bestens geeignet
- Austausch- und wendbare Aufsatzbacken

Avantages:

- Meilleure accessibilité
- reconfiguration rapide par simple pression sur un bouton et entièrement sans outil
- Forces de serrage les plus élevées
- Résistant à la saleté sur tous les côtés écoulement de copeaux libre
- Inserts de serrage remplaçables et réutilisables avec différents contours
- Trous d'adaptateur standard sur la vitesse hemo.change 30 et autres systèmes de serrage et de palettisation à point zéro
- Idéal pour les pièces brutes et finies
- Mâchoires de serrage interchangeables et réversibles

Advantages:

- Best accessibility
- quick retooling at the push of a button and completely tool-free
- Highest clamping forces
- Resistant to dirt on all sides free chip flow
- Replaceable and reusable clamping inserts with different contours
- Standard adapter holes on speed.change 30 and other zero point clamping and palletizing systems
- Ideal for raw and finished parts
- Interchangeable and reversible clamping jaws

Modularer Aufbau | Construction modulaire | Modular design

Spanneinsätze
Inserts de serrage
Clamping inserts



Seite | Page | Page **19**

Aufsatzbacken und Zubehör

Mors de base et accessoires

Base jaws and accessories



Seite | Page | Page **21**

Spannmittel varia Polytec

Etau à serrage varia Plus

Vice varia Plus



Seite | Page | Page **11**

Zubehör für Montage auf Maschinentisch

Accessoires pour la montage sur table de machine

Accessories for mounting on machine table



(Katalog) Seite | Page | Page **116**

Maschinentisch

Table de machine

Machine table

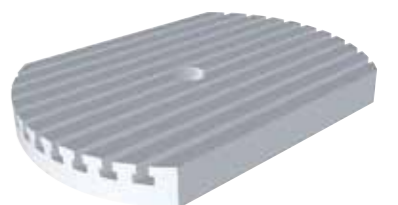

1 Wahl der Aufsatzbacken
Choix de mors de mâchoires
Exchangeable jaw selection

Breite
Largeur
Width

78 mm



Z 78WS

Seite | Page | Page 21



Z 114WS

Seite | Page | Page 21

114 mm

Für Spanneinsätze
pour inserts de serrage / for clamping inserts

Stufen geschliffen
Meulage par ét./ Step Ground Mach.



Z 114WY1

Seite | Page | Page 21

114 mm

Bearbeitbar
Usinables / Machinable



Z 114WB

Seite | Page | Page 21

114 mm

2 Wahl der Grundplatte
Choix de plaque de base
Base pick selection

Spannbereich (Grundplatte)
Plage de serrage (Plaque de base)
Clamping range (Base plate)

6 - 306 mm
(320 mm)



Q-320G

6 - 506 mm
(520 mm)



Q-520G

3 Wahl der Adapterbohrung
Choix de alésage d'adaptation
Choice of adapter boreholes

Adapterbohrung
Alésages d'adaptation
Adapter boreholes

ohne
sans
without

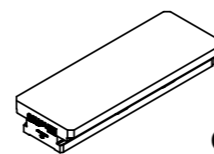

0

speed.change 30
EROWA VPC 96 / Quick-Point 96
R50 M12 / R50 M8
Passnuten 20H7

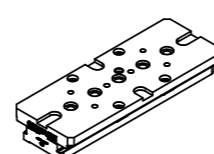

1

kundenspezifisch
spécifique au client
customer-specific

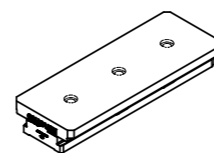

2

speed.change 30
EROWA VPC 96
Quick-Point 96

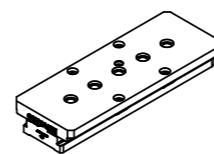

3

R50 M12

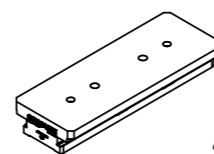

4

speed.change 30

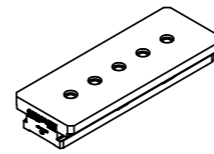

5

Quick-Point 96

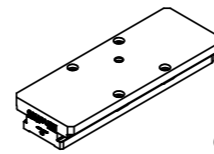

6



Hier gehts zur
Lochbildvermessung vom
varia Polytec

4 Wahl des Spanneinsatzes
Choix de insert de serrage
Clamping selection

Typ
Type
Type

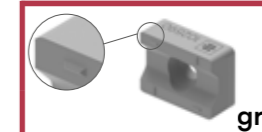

gr

hemo Grip
hemo Grip
hemo Grip

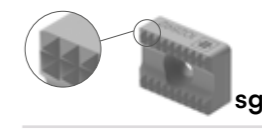

sg

spitz geriffelt
rainurage pointu
pointed corrugation

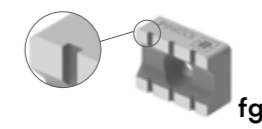

fg

flach geriffelt
rainurage plat
flat corrugation

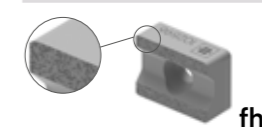

fh

flach, Hartmetall beschichtet
plane, peinte de métal dur
flat, hard metal coated

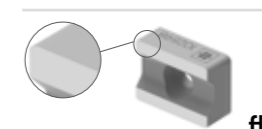

fl

flach
plane
flat

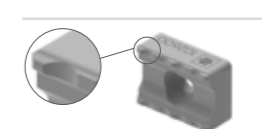

ps

für Prägesysteme
pur le système de gaufrage
for pres clamping system

Seite | Page | Page 13

Bestellbeispiel
Exemple de commande
Order example

ZQ114WB-520G-4

Bestellbeispiel
Exemple de commande
Order example

ZQ114WS-320G-1-gr



varia Polytec

varia Polytec	A ¹	A ²	A ³	B ¹	B ²	C ¹	C ²	D ¹	D ²	D ³	D ⁴	D ⁵	E ¹
ZQ78WS-320G-_-_-	120	114	78	6-106	86-186	320	224	50	65	140	148.5	151.5	15
ZQ114WS-320G-_-_-	120	114	114	6-106	86-186	320	224	50	65	140	148.5	151.5	15
ZQ78WS-520G-_-_-	120	114	78	6-306	86-386	520	224	50	65	140	148.5	151.5	15
ZQ114WS-520G-_-_-	120	114	114	6-306	86-386	520	224	50	65	140	148.5	151.5	15

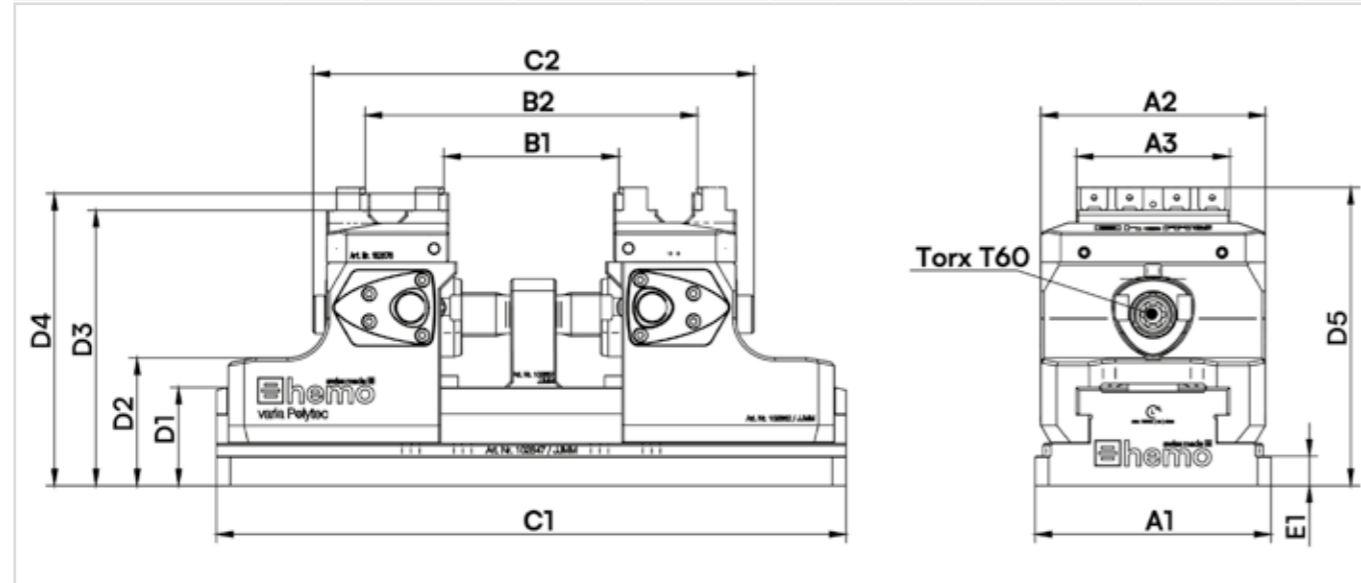

varia Polytec	F ¹	F ²
ZQ78WS-320G-_-_-	124-226	204-306
ZQ114WS-320G-_-_-	124-226	204-306
ZQ78WS-520G-_-_-	124-426	204-506
ZQ114WS-520G-_-_-	124-426	204-506

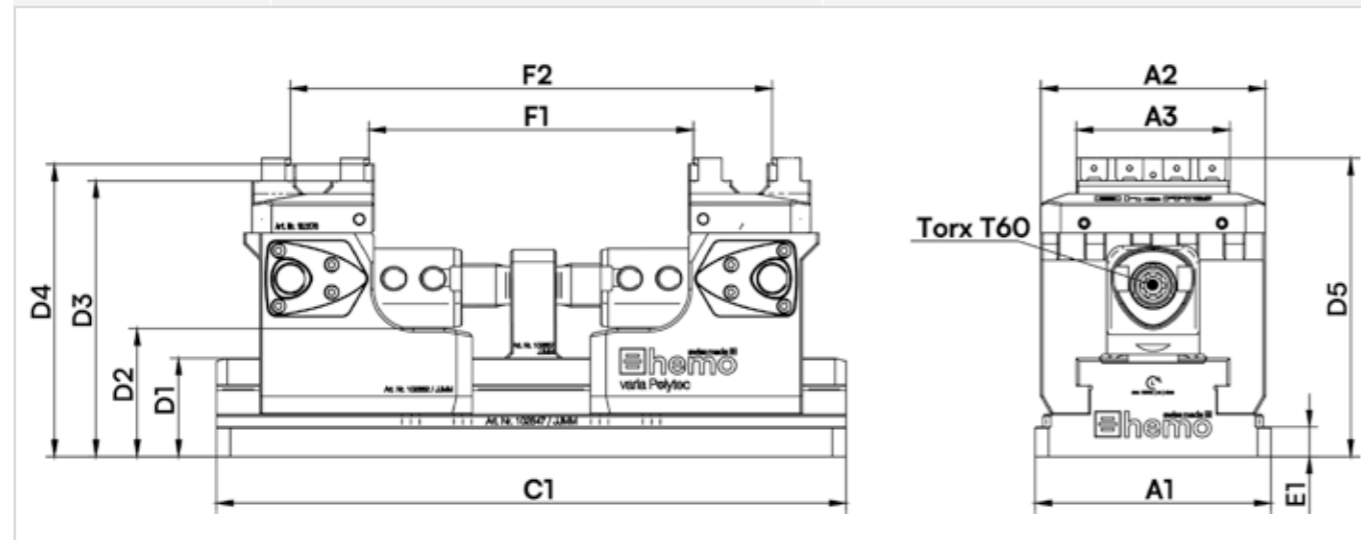

Technische Informationen | Information techniques | Technical information

Max. Spannkraft (kN) Force de serrage max. (kN) Max. Clamp Force (kN)	Max. Anzugs-Drehmoment (Nm) Couple max. (Nm) Max. Torque (Nm)	Wiederholgenauigkeit (mm) Répétabilité (mm) Repeatability (mm)
50	100	≤ 0.01

Spannkraftdiagramm | Diagramme de tension-force | Clamping force diagram

Gemessen am Werkstück in Produktionsumgebung mit Kühlschmierstoffemulsion. DIN 6386: Die Spannkraft ist die Summe aller auf das Werkstück wirkenden Backenkräfte.

Mesurée sur la pièce dans un environnement de production avec émulsion de lubrifiant réfrigérant. DIN 6386: La force de serrage est la somme de toutes les forces des mâchoires agissant sur la pièce d'usinage.

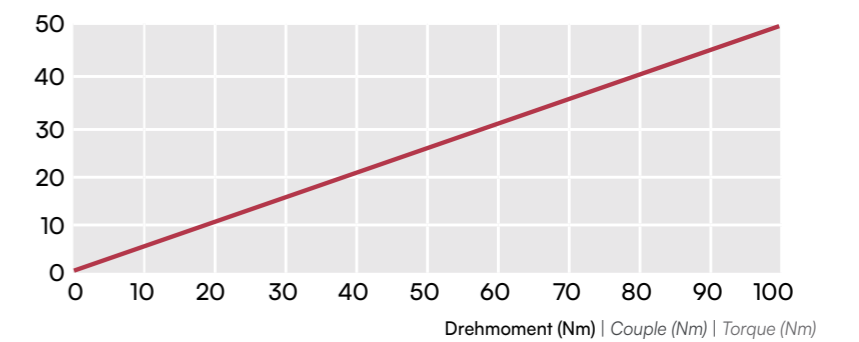

Measured on the workpiece in production environment with cooling lubricant emulsion. DIN 6386: The clamping force is the sum of all jaw forces impacting on the workpiece.

Spannkraft (kN) | Force de serrage (kN) | Clamping Force (kN)







varia Polytec mit Aufsatzbacken Z 78WS

Bezeichnung Description Description	Artikelnr. Nr.d'article Article No.	Spannbereich Cap.serrage Clamp. range	Spannkraft F. serrage Cl. force	Spannhub C. de serrage Cl. stroke	Gewicht Poids Weight	Masse (mm) Dimensions (mm) Dimensions (mm)											Lieferumfang Éléments livrés Scope of Delivery		
						A ¹	A ²	A ³	B ¹	B ²	C ¹	C ²	D ¹	D ²	D ³	D ⁴			D ⁵
varia Polytec ZQ78WS-320G																			
 ohne Adapterbohrungen (0) sans alésages d'adaptation (0) without adapter boreholes (0)	102924	6-306mm	50kN	102mm	22kg	120	114	78									124 - 226	204 - 306	1x Grundplatte mit Spindel 2x Polygonhülsen 2x Grundbacken 2x 102879 Aufsatzbacke Z78WS 8x Spanneinsätze (nach Ihrer Wahl) 2x 102604 Werkstückauflage 10x 102609 Schrauben M3.5 1x 102619 Föhnenschlüssel 1x 102880 Handrad 1x 104116 Hebevorrichtung 2x Ausrichtbolzen 1x plaque de base avec broche 2x douilles polygonales 2x mors de base 2x mors rapportés 102879 Z78WS 8x inserts de serrage (au choix) 2x supports de pièce 102604 10x vis 102609 M3.5 1x clé en drapeau 102619 1x volant 102880 1x dispositif de levage 104116 2x goujons d'alignement 1x base plate with spindle 2x polygon sleeves 2x base jaws 2x top jaws 102879 Z78WS 8x clamping inserts (of your choice) 2x workpiece supports 102604 10x screws 102609 M3.5 1x flag wrench 102619 1x handwheel 102880 1x lifting device 104116 2x alignment pins
Adapterbohrungen 1 perçages d'adaptation 1 adapter boreholes 1	102925																		
Adapterbohrungen 2 perçages d'adaptation 2 without adapter boreholes 2	102926																		
Adapterbohrungen 3 perçages d'adaptation 3 adapter boreholes 3	102927																		
Adapterbohrungen 4 perçages d'adaptation 4 adapter boreholes 4	102928																		
Adapterbohrungen 5 perçages d'adaptation 5 adapter boreholes 5	102929																		
Adapterbohrungen 6 perçages d'adaptation 6 adapter boreholes 6	ZQ78WS-320G-6-__																		
varia Polytec ZQ78WS-520G																			
 ohne Adapterbohrungen (0) sans alésages d'adaptation (0) without adapter boreholes (0)	ZQ78WS-520G-0-__	6-506mm	50kN	102mm	32kg	120	114	78									124 - 426	204 - 506	1x Grundplatte mit Spindel 2x Polygonhülsen 2x Grundbacken 2x 102879 Aufsatzbacke Z78WS 8x Spanneinsätze (nach Ihrer Wahl) 2x 102604 Werkstückauflage 10x 102609 Schrauben M3.5 1x 102619 Föhnenschlüssel 1x 102880 Handrad 1x 104116 Hebevorrichtung 2x Ausrichtbolzen 1x plaque de base avec broche 2x douilles polygonales 2x mors de base 2x mors rapportés 102879 Z78WS 8x inserts de serrage (au choix) 2x supports de pièce 102604 10x vis 102609 M3.5 1x clé en drapeau 102619 1x volant 102880 1x dispositif de levage 104116 2x goujons d'alignement 1x base plate with spindle 2x polygon sleeves 2x base jaws 2x top jaws 102879 Z78WS 8x clamping inserts (of your choice) 2x workpiece supports 102604 10x screws 102609 M3.5 1x flag wrench 102619 1x handwheel 102880 1x lifting device 104116 2x alignment pins
Adapterbohrungen 1 perçages d'adaptation 1 adapter boreholes 1	ZQ78WS-520G-1-__																		
Adapterbohrungen 2 perçages d'adaptation 2 without adapter boreholes 2	ZQ78WS-520G-2-__																		
Adapterbohrungen 3 perçages d'adaptation 3 adapter boreholes 3	ZQ78WS-520G-3-__																		
Adapterbohrungen 4 perçages d'adaptation 4 adapter boreholes 4	ZQ78WS-520G-4-__																		
Adapterbohrungen 5 perçages d'adaptation 5 adapter boreholes 5	ZQ78WS-520G-5-__																		
Adapterbohrungen 6 perçages d'adaptation 6 adapter boreholes 6	ZQ78WS-520G-6-__																		

varia Polytec mit Aufsatzbacken Z 114WS





Bezeichnung Description Description	Artikelnr. Nr.d'article Article No.	Spannbereich Cap.serrage Clamp. range	Spannkraft F. serrage Cl. force	Spannhub C. de serrage Cl. stroke	Gewicht Poids Weight	Masse (mm) Dimensions (mm) Dimensions (mm)												Lieferumfang Éléments livrés Scope of Delivery		
						A ¹	A ²	A ³	B ¹	B ²	C ¹	C ²	D ¹	D ²	D ³	D ⁴	D ⁵	E ¹	F ¹	F ²
varia Polytec ZQ114WS-320G																				
 ohne Adapterbohrungen(0) sans alésages d'adaptation (0) without adapter boreholes(0)	102840	6-306mm	50kN	102mm	22kg	120	114	114									15	124 - 226	204 - 306	1x Grundplatte mit Spindel 2x Polygonhülsen 2x Grundbacken 2x 102873 Aufsatzbacke Z114WS 12x Spanneinsätze 2x 102875 Werkstückauflage 14x 102609 Schrauben M3.5 1x 102619 Föhnenschlüssel 1x 102880 Handrad 1x 104116 Hebevorrichtung 2x Ausrichtbolzen 1x plaque de base avec broche 2x douilles polygonales 2x mors de base 2x mors rapportés 102873 Z114WS 12x inserts de serrage (au choix) 2x supports de pièce 102875 14x vis 102609 M3.5 1x clé en drapeau 102619 1x volant 102880 1x dispositif de levage 104116 2x goujons d'alignement 1x base plate with spindle 2x polygon sleeves 2x base jaws 2x top jaws 102873 Z114WS 12x clamping inserts (of your choice) 2x workpiece supports 102875 14x screws 102609 M3.5 1x flag wrench 102619 1x handwheel 102880 1x lifting device 104116 2x alignment pins
Adapterbohrungen 1 perçages d'adaptation 1 adapter boreholes 1	102841																			
Adapterbohrungen 2 perçages d'adaptation 2 without adapter boreholes 2	102842																			
Adapterbohrungen 3 perçages d'adaptation 3 adapter boreholes 3	102843																			
Adapterbohrungen 4 perçages d'adaptation 4 adapter boreholes 4	102844																			
Adapterbohrungen 5 perçages d'adaptation 5 adapter boreholes 5	102845																			
Adapterbohrungen 6 perçages d'adaptation 6 adapter boreholes 6	102846																			
varia Polytec ZQ114WS-520G																				
 ohne Adapterbohrungen(0) sans alésages d'adaptation (0) without adapter boreholes(0)	ZQ114WS-520G-0-__	6-506mm	50kN	102mm	32kg	120	114	114									15	124 - 426	204 - 506	1x Grundplatte mit Spindel 2x Polygonhülsen 2x Polygonhülsen lang 2x Grundbacken 2x 102873 Aufsatzbacke Z114WS 12x Spanneinsätze 2x 102875 Werkstückauflage 14x 102609 Schrauben M3.5 1x 102619 Föhnenschlüssel 1x 102880 Handrad 1x 104069 Handrad lang 1x 104116 Hebevorrichtung 2x Ausrichtbolzen 1x plaque de base avec broche 2x douilles polygonales 2x mors de base 2x mors rapportés 102873 Z114WS 12x inserts de serrage (au choix) 2x supports de pièce 102875 14x vis 102609 M3.5 1x clé en drapeau 102619 1x volant 102880 1x dispositif de levage 104116 2x goujons d'alignement 1x base plate with spindle 2x polygon sleeves 2x base jaws 2x top jaws 102873 Z114WS 12x clamping inserts (of your choice) 2x workpiece supports 102875 14x screws 102609 M3.5 1x flag wrench 102619 1x handwheel 102880 1x lifting device 104116 2x alignment pins
Adapterbohrungen 1 perçages d'adaptation 1 adapter boreholes 1	ZQ114WS-520G-1-__																			
Adapterbohrungen 2 perçages d'adaptation 2 without adapter boreholes 2	ZQ114WS-520G-2-__																			
Adapterbohrungen 3 perçages d'adaptation 3 adapter boreholes 3	ZQ114WS-520G-3-__																			
Adapterbohrungen 4 perçages d'adaptation 4 adapter boreholes 4	ZQ114WS-520G-4-__																			
Adapterbohrungen 5 perçages d'adaptation 5 adapter boreholes 5	ZQ114WS-520G-5-__																			
Adapterbohrungen 6 perçages d'adaptation 6 adapter boreholes 6	ZQ114WS-520G-6-__																			



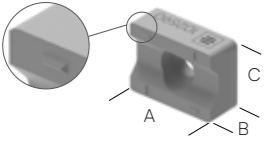
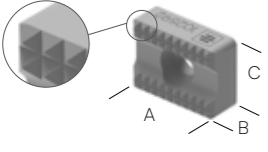
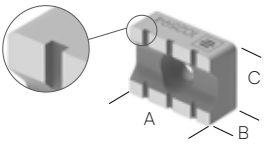
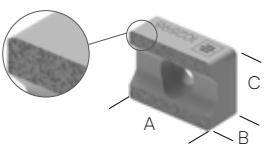
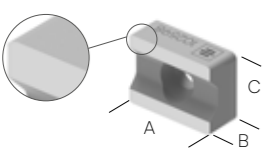
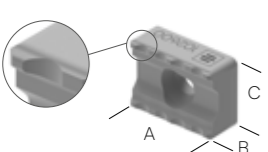

varia Polytec mit Aufsatzbacken Z 114WY1

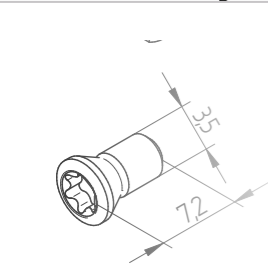
Bezeichnung <i>Description</i> <i>Description</i>	Artikelnr. <i>Nr.d'article</i> <i>Article No.</i>	Spannbereich <i>Cap.serrage</i> <i>Clamp. range</i>	Spannkraft <i>F. serrage</i> <i>Cl. force</i>	Spannhub <i>C. de serrage</i> <i>Cl. stroke</i>	Gewicht <i>Poids</i> <i>Weight</i>	Masse (mm) <i>Dimensions (mm)</i> <i>Dimensions (mm)</i>														Lieferumfang <i>Éléments livrés</i> <i>Scope of Delivery</i>	
						A ¹	A ²	A ³	B ¹	B ²	C ¹	C ²	D ¹	D ²	D ³	D ⁴	D ⁵	E ¹	F ¹		F ²
varia Polytec ZQ114WY1-320G		6-306mm	50kN	102mm	22kg	120	114	114	-	-	320	224	50	65	140	148.5	151.5	15	124 - 226	204 - 306	1x Grundplatte mit Spindel 2x Polygonhülsen 2x Grundbacken 2x 102906 Aufsatzbacke Z114WY1 1x 102880 Handrad 1x 104116 Hebevorrichtung 2x Ausrichtbolzen
ohne Adapterbohrungen(0) <i>sans alésages d'adaptation (0)</i> <i>without adapter boreholes (0)</i>	ZQ114WY1-320G-0																				<i>1x plaque de base avec broche</i> <i>2x douilles polygonales</i> <i>2x mors de base</i> <i>2x mors rapportés 102906 Z114WY1</i> <i>1x volant 102880</i> <i>1x dispositif de levage 104116</i> <i>2x goujons d'alignement</i>
Adapterbohrungen 1 <i>perçages d'adaptation 1</i> <i>adapter boreholes 1</i>	ZQ114WY1-320G-1																				
Adapterbohrungen 2 <i>perçages d'adaptation 2</i> <i>without adapter boreholes 2</i>	ZQ114WY1-320G-2																				
Adapterbohrungen 3 <i>perçages d'adaptation 3</i> <i>adapter boreholes 3</i>	ZQ114WY1-320G-3																				
Adapterbohrungen 4 <i>perçages d'adaptation 4</i> <i>adapter boreholes 4</i>	ZQ114WY1-320G-4																				
Adapterbohrungen 5 <i>perçages d'adaptation 5</i> <i>adapter boreholes 5</i>	ZQ114WY1-320G-5																				
Adapterbohrungen 6 <i>perçages d'adaptation 6</i> <i>adapter boreholes 6</i>	ZQ114WY1-320G-6																				
varia Polytec ZQ114WY1-520G		6-506mm	50kN	102mm	32kg	120	114	114	-	-	520	224	50	65	140	148.5	151.5	15	124 - 426	204 - 506	1x Grundplatte mit Spindel 2x Polygonhülsen 2x Polygonhülsen lang 2x Grundbacken 2x 102906 Aufsatzbacke Z114WY1 1x 102880 Handrad 1x 104069 Handrad lang 1x 104116 Hebevorrichtung 2x Ausrichtbolzen
ohne Adapterbohrungen(0) <i>sans alésages d'adaptation (0)</i> <i>without adapter boreholes (0)</i>	ZQ114WY1-520G-0																				<i>1x plaque de base avec broche</i> <i>2x douilles polygonales</i> <i>2x mors de base</i> <i>2x mors rapportés 102906 Z114WY1</i> <i>1x volant 102880</i> <i>1x dispositif de levage 104116</i> <i>2x goujons d'alignement</i>
Adapterbohrungen 1 <i>perçages d'adaptation 1</i> <i>adapter boreholes 1</i>	ZQ114WY1-520G-1																				
Adapterbohrungen 2 <i>perçages d'adaptation 2</i> <i>without adapter boreholes 2</i>	ZQ114WY1-520G-2																				
Adapterbohrungen 3 <i>perçages d'adaptation 3</i> <i>adapter boreholes 3</i>	ZQ114WY1-520G-3																				
Adapterbohrungen 4 <i>perçages d'adaptation 4</i> <i>adapter boreholes 4</i>	ZQ114WY1-520G-4																				
Adapterbohrungen 5 <i>perçages d'adaptation 5</i> <i>adapter boreholes 5</i>	ZQ114WY1-520G-5																				
Adapterbohrungen 6 <i>perçages d'adaptation 6</i> <i>adapter boreholes 6</i>	ZQ114WY1-520G-6																				

Spanneinsätze und weiteres Zubehör | Inserts de serrage et autres accessoires



Clamping inserts and additional accessories

Bezeichnung Description Description	Artikelnr. Numéro d'article Article No.	Masse (mm) Dimensions (mm) Dimensions (mm)				Passend zu Backen compatible avec compatible with						Lieferumfang Éléments livrés Scope of Delivery
		A	B	C	D	varia Plus			varia Polytec & G inverse			
						Z42S	Z78S	Z78B	Z 78WS	Z 114WS	Z 114WB	
 Spanneinsatz-gr hemo Grip Insert de serrage-gr hemo Grip clamping insert-gr hemo Grip	102590											1 Stk. Spanneinsatz (exkl. Schrauben)
	102891	14	5	10	-	●	●	●	●	●	●	6 Stk. Spanneinsätze (inkl. 2 Stk. 102609 Schrauben)
	102812											8 Stk. Spanneinsätze (inkl. 2 Stk. 102609 Schrauben)
	102591											10 Stk. Spanneinsätze (exkl. Schrauben)
 Spanneinsatz-sg spitz geriffelt Insert de serrage-sg à rainurage pointu clamping insert-sg pointed corrugation	102592											
	102892	14	5	10	-	●	●	●	●	●	●	6 Stk. Spanneinsätze (inkl. 2 Stk. 102609 Schrauben)
	102813											8 Stk. Spanneinsätze (inkl. 2 Stk. 102609 Schrauben)
	102593											10 Stk. Spanneinsätze (exkl. Schrauben)
 Spanneinsatz-fg flach geriffelt Insert de serrage-fg à rainurage plat clamping insert-fg flat corrugation	102594											
	102893	14	5	10	-	●	●	●	●	●	●	6 Stk. Spanneinsätze (inkl. 2 Stk. 102609 Schrauben)
	102814											8 Stk. Spanneinsätze (inkl. 2 Stk. 102609 Schrauben)
	102595											10 Stk. Spanneinsätze (exkl. Schrauben)
 Spanneinsatz-fh flach, Hartmetall beschichtet Insert de serrage-fh plane, peinte de métal dur clamping insert-fh flat, hard metal coated	102596											
	102894	14	5	10	-	●	●	●	●	●	●	6 Stk. Spanneinsätze (inkl. 2 Stk. 102609 Schrauben)
	102815											8 Stk. Spanneinsätze (inkl. 2 Stk. 102609 Schrauben)
	102597											10 Stk. Spanneinsätze (exkl. Schrauben)
 Spanneinsatz-fl flach Insert de serrage-fl plane clamping insert-fl flat	102598											
	102895	14	5	10	-	●	●	●	●	●	●	6 Stk. Spanneinsätze (inkl. 2 Stk. 102609 Schrauben)
	102816											8 Stk. Spanneinsätze (inkl. 2 Stk. 102609 Schrauben)
	102599											10 Stk. Spanneinsätze (exkl. Schrauben)
 Spanneinsatz-ps für Prägesysteme Insert de serrage-ps pur le système de gaufrage clamping insert-ps for pres clamping system	102600											
	102896	14	5	10	-	●	●	●	●	●	●	6 Stk. Spanneinsätze (inkl. 2 Stk. 102609 Schrauben)
	102817											8 Stk. Spanneinsätze (inkl. 2 Stk. 102609 Schrauben)
	102601											10 Stk. Spanneinsätze (exkl. Schrauben)
 Abdeckung für Spanneinsatztaschen Couverture pour les poches d'insertion de serrage Cover for clamping insert pockets	102602											
	102897	14	4	10	-	●	●	●	●	●	●	6 Stk. Abdeckungen (inkl. 2 Stk. 102609 Schrauben)
	102818											8 Stk. Abdeckungen (inkl. 2 Stk. 102609 Schrauben)
	102603											10 Stk. Abdeckungen (exkl. Schrauben)
 Schraube für Spanneinsätze und Werkstückauflagen varia Produktfa- milie, TX15 Antrieb Vis pour inserts de serrage et supports de pièce famille de produits varia, entraînement TX15 Screw for clamping inserts and workpiece supports varia product family, TX15 drive	102609											-
	102610	-	7.2	-	M 3.5	●	●		●	●		10 Stk. Schrauben
 Fähnchenschlüssel TX15 passend zur Schraube 102609 Clé en drapeau TX15 compatible avec la vis 102609 Flag wrench TX15 suitable for screw 102609	102619	-	-	-	-	●	●		●	●		1 Stk. Fähnchenschlüssel

Grund- und Aufsatzbacken varia Produktfamilie mors de base et mors rapportés			famille de produits varia base jaws and top jaws varia product family		
Bezeichnung Description Description	Artikelnr. Numéro d'article Article No.		Passend zu compatible avec compatible with		Lieferumfang Éléments livrés Scope of Delivery
			varia Polytec	varia G inverse	
 Aufsatzbacke Z 78WS Mors rapporté Z 78WS Top jaw Z 78WS	Paar paire pair 102878				Paar: 2 Stk. Aufsatzbacken B = 78mm für 4 Spanneinsätze pro Backenseite Paire : 2 mors rapportés B = 78mm pour inserts de serrage Pair: 2 top jaws B = 78mm for clamping inserts
	Einzelteil pièce unique single part 102879				
 Aufsatzbacke Z 114WS Mors rapporté Z 114WS Top jaw Z 114WS	Paar paire pair 102872				Paar: 2 Stk. Aufsatzbacken B = 114mm für 6 Spanneinsätze pro Backenseite Paire : 2 mors rapportés B = 114mm pour inserts de serrage Pair: 2 top jaws B = 114mm for clamping inserts
	Einzelteil pièce unique single part 102873				
 Aufsatzbacke Z 114WY1 Mors rapporté Z 114WY1 Top jaw Z 114WY1	Paar paire pair 102905				Paar: 2 Stk. Aufsatzbacken B = 114mm, flach geschliffen mit Stufen auf der Innen- und Ausenseite Paire : 2 mors rapportés B = 114mm, rectifiés à plat avec des étapes sur les faces intérieure et extérieure Pair: 2 top jaws B = 114mm, flat ground with steps on the inside and outside
	Einzelteil pièce unique single part 102906				
 Aufsatzbacke Z 114WB Mors rapporté Z 114WB Top jaw Z 114WB	Paar paire pair 102876				Paar: 2 Stk. Aufsatzbacken B = 114mm für Formbacken Paire : 2 mors rapportés B = 114mm pour mors profilés Pair: 2 top jaws B = 114mm for form jaws
	Einzelteil pièce unique single part 102877				

Zubehör varia Produktfamilie | Accessoires famille de produits varia

Accessories varia product family

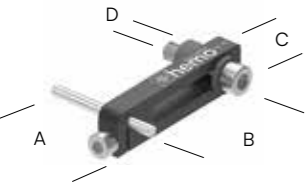
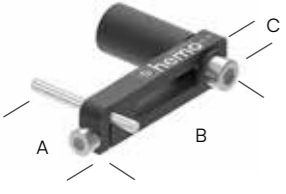
Bezeichnung Description Description	Artikelnr. Numéro d'article Article No.	Masse (mm) Dimensions (mm) Dimensions (mm)				Passend zu Backen compatible avec compatible with						Lieferumfang Eléments livrés Scope of Delivery		
		A	B	C	D	varia Plus			varia Polytec und G inverse					
						Z42S	Z78S	Z78B	Z 78WS	Z 114WS	Z 114WB			
 <p>Werkstückauflage 78S-M mit vier Taschen für Spanneinsätze <i>Support de pièce 78S-M</i> vec quatre poches pour inserts de serrage <i>Workpiece support 78S-M</i> with four pockets for clamping inserts</p>	102604	-	-	-	-									<p>1 Stk. Werkstückauflage (exkl. Schraube) <i>1 pièce de support de pièce (hors vis)</i> <i>1 piece of workpiece support (excluding screw)</i></p>
 <p>Werkstückauflage 114S-M mit sechs Taschen für Spanneinsätze <i>Support de pièce 114S-M</i> vec six poches pour inserts de serrage <i>Workpiece support 114S-M</i> with six pockets for clamping inserts</p>	102875	-	-	-	-									<p>1 Stk. Werkstückauflage (exkl. Schraube) <i>1 pièce de support de pièce (hors vis)</i> <i>1 piece of workpiece support (excluding screw)</i></p>
 <p>Seitenanschlag geschraubt <i>butée latérale vissée</i> <i>side stop screwed</i></p>	100884	40	60	15	M6									<p>1 Stk. inkl. Schraube und Distanzstück <i>1 pièce avec vis de fixation et entretoise</i> <i>1 piece including fastening screw and spacer</i></p>
 <p>Seitenanschlag magnetisch <i>butée latérale magnétique</i> <i>side stop magnetic</i></p>	100198	70	70	20	-									<p>1 Stk. inkl. Schraube und magnetischem Distanzstück <i>1 pièce avec vis de fixation et entretoise magnétique</i> <i>1 piece including fastening screw and magnetic spacer</i></p>

Zubehör varia Produktfamilie | Accessoires famille de produits varia

Accessories varia product family

Bezeichnung Description Description	Artikelnr. Numéro d'article Article No.		Passend zu Grundplattengrößen compatible avec compatible with			Lieferumfang Éléments livrés Scope of Delivery
			varia Polytec		varia G inverse	
			320-G	520-G	alle Größen	
 <p>Handrad Torx T60 auf 1/2" Länge 100mm Volant Torx T60 à 1/2" handwheel Torx T60 to 1/2"</p>	102880		•	•		<p>1 Stk. Handrad 1 pièce de volant 1 piece of handwheel</p>
 <p>Handrad Torx T60 auf 1/2" Länge 200mm Volant Torx T60 à 1/2" handwheel Torx T60 to 1/2"</p>	104069			•		<p>1 Stk. Handrad 1 pièce de volant 1 piece of handwheel</p>
 <p>Hebevorrichtung zum Anheben mittels Kran oder Kettenzug Dispositif de levage pour élévation par grue ou palan Lifting device for lifting by crane or chain hoist</p>	104116		•	•	•	<p>1 Stk. Hebevorrichtung inkl. Ringschraube 1 pièce de dispositif de levage avec œillet 1 piece lifting device including eye bolt</p>



swiss made 
hemo

swiss made 
hemo

swiss made 
hemo

VARIA POLYTEC

Mit einem Klick von klein zu gross.

Mit einem Klick von klein zu gross. Die patentierte hemo Backenschnellverstellung erlaubt ein Umrüsten von minimaler zu maximaler Spannweite in Sekunden

Système de réglage rapide des mors en un clic.

D'un clic, passez de petit à grand. Le système de réglage rapide des mors breveté de hemo permet de passer en quelques secondes de la plage de serrage minimale à la plage maximale.

Quick jaw-adjustment unit with one click.

With a click from small to large. The patented hemo quick-jaw adjustment system allows switching from minimal to maximal clamping range in seconds.



SCAN
ME



Stehen Sie vor weiteren Herausforderungen in Ihrer täglichen Arbeit?

Wir bieten eine breite Palette an Spannmitteln und unterstützen Sie gerne mit der passenden Lösung. Besuchen Sie uns eine Mail auf info@hemo.ch oder rufen Sie uns an unter +41 (0) 41 348 04 04. Wir sind bereit für Ihre Herausforderungen!





Faites-vous face à de nouveaux défis dans votre travail quotidien ?

Nous proposons une large gamme de solutions de serrage et vous accompagnons avec la solution adaptée. Envoyez-nous un e-mail à info@hemo.ch ou appelez-nous au +41 (0) 41 348 04 04. Nous sommes prêts à relever vos défis!

Are you facing further challenges in your daily work?

We offer a wide range of clamping solutions and are happy to support you with the right solution. Send us an email at info@hemo.ch or call us at +41 (0) 41 348 04 04. We are ready for your challenges!

			
varia Mini Unsere Mini-Lösung für Ihre grossen Probleme Der kleine überzeugt durch 12kN Spannkraft und der gewohnten hemo Präzision von ≤ 0.01 mm Notre solution mini pour vos grands problèmes Ce petit dispositif convainc par une force de serrage de 12 kN et la précision habituelle de hemo de $\leq 0,01$ mm. Our mini solution for your big problems The small one impresses with 12 kN clamping force and the usual hemo precision of ≤ 0.01 mm.	varia Plus Willkommen in der Welt der Varianten Mit dem varia Plus haben wir die erfolgreiche varia Produktfamilie gestartet. Mehr Spannkraft, Zugänglichkeit, Präzision und Modularität für beste Ergebnisse. Bienvenue dans le monde des variantes Avec le varia Plus, nous avons lancé la famille de produits varia. Plus de force de serrage, d'accessibilité, de précision et de modularité pour des résultats optimaux. Welcome to the world of variants With varia Plus, we launched the successful varia product family. More clamping force, accessibility, precision, and modularity for optimal results.	varia Polytec Mit einem Klick von klein zu gross Mit einem Klick von klein zu gross. Die patentierte hemo Backenschnellverstellung erlaubt ein Umrüsten von minimaler zu maximaler Spannweite in Sekunden Système de réglage rapide des mors en un clic D'un clic, passez de petit à grand. Le système de réglage rapide des mors breveté de hemo permet de passer en quelques secondes de la plage de serrage minimale à la plage maximale. Quick jaw-adjustment unit with one click With a click from small to large. The patented hemo quick-jaw adjustment system allows switching from minimal to maximal clamping range in seconds.	varia G inverse Der niedrige Allrounder Ideal für tägliche Aufgaben im 3- und 5-Achsbereich. Die kompakte Bauweise bietet Flexibilität und Präzision in engen Arbeitsräumen und gewährleistet zuverlässige Leistung. Le modèle bas polyvalent Idéal pour les tâches quotidiennes en applications 3 et 5 axes. Sa conception compacte offre flexibilité et précision dans les espaces réduits tout en garantissant des performances fiables. The low-level allrounder Ideal for daily tasks in 3- and 5-axis applications. The compact design provides flexibility and precision in tight spaces while ensuring reliable performance.

			
optima II Das kleine Kraftpaket Für die erste und zweite Aufspannung. Mit einer Spannkraft von 30 kN und einer Wiederholgenauigkeit von 0.01 mm. Le petit paquet de force Pour le premier et le deuxième serrage. Avec une force de serrage de 30 kN et une répétabilité de 0.01 mm. The small power pack For the first and second clamping processes, with a clamping power of 30 kN and a repeatability, precision and modularity for the best production results.	optima Der Preiswerte Bestens geeignet für Ihre Ansprüche in der ersten und zweiten Aufspannung bei einer Wiederholgenauigkeit von 0.01 mm. Le moins cher Parfaitement adapté aux exigences d'un premier et second serrage pour une épétabilité de 0.01 mm. The best value Perfectly meets your requirements, repeat accuracy of 0.01 mm in the first and second clamping assembly.	basic Der Allrounder Bestens geeignet für Ihre Ansprüche in der ersten und zweiten Aufspannung bei einer Wiederholgenauigkeit von 0.005mm. Le polyvalent Parfaitement adapté aux exigences d'un premier et second serrage pour une répétabilité de 0.005mm. The All-rounder Perfectly meets your requirements, repeat accuracy of 0.005 mm in the first and second clamping assembly.	hi-tec Das Kraftpaket Kombiniert die Bedürfnisse bei der CNC-5-Achsen-Bearbeitung: eine Wiederholgenauigkeit von 0.003 mm und eine Spannkraft von 57 kN. Le puissant Combine les besoins pour un usinage à 5 axes sur commande numérique: une répétabilité de 0.003 mm et une force de serrage de 57 kN. The power horse Meets all the combined needs of CNC 5-axis machining: a repeat accuracy of 0.003 mm and a clamping force of 57 kN.

Hersteller:

hemo AG

Dattenmattstrasse 12

CH-6010 Kriens

Telefon+41 (0) 41 348 04 04

info@hemo.ch

Folgen Sie uns auf



Vertrieb:

